

# CAP

## SCOPE AND ACTIVITY FOR 2021

CCI / 2021 - 11 - 30

from knowledge  
generation to  
science-based  
innovation

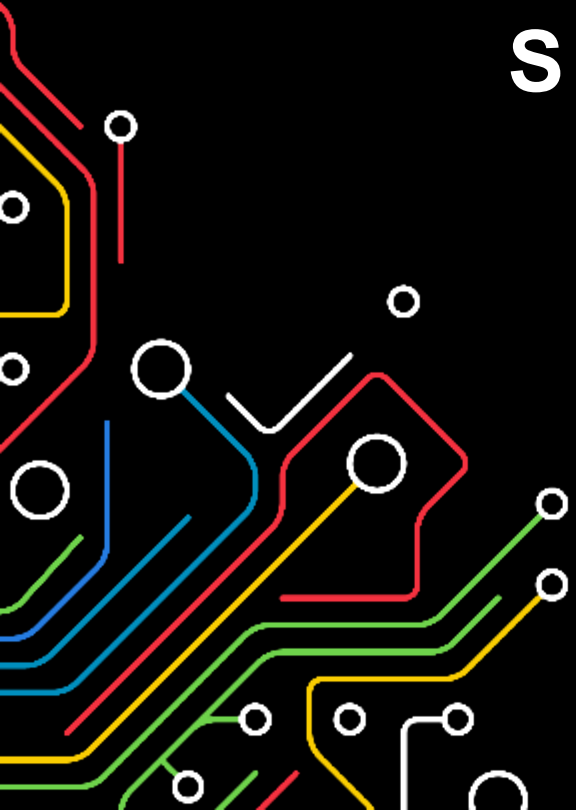

# CAP RESEARCH LINES

- **Optical Sensors** (Pedro Jorge & Orlando Frazão)
- **Quantum optical engineering** (Ariel Guerreiro)
- **Advanced Optical Imaging** (Carla Rosa)
- **Integrated Optics and Microfabrication** (Paulo Marques)

## Physical sensors (Orlando Frazão)

- ✓ New design of interferometers: Mach Zehnder, spatial filter and Fabry-Perot with high finesse
- ✓ High sensitivity and resolution
- ✓ High radiation and temperature environments

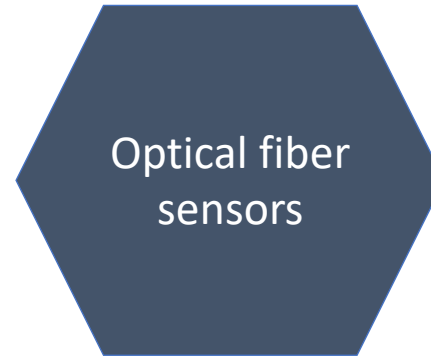
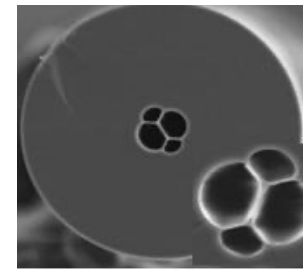
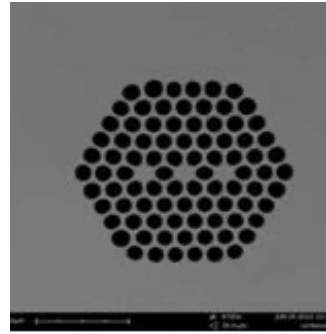
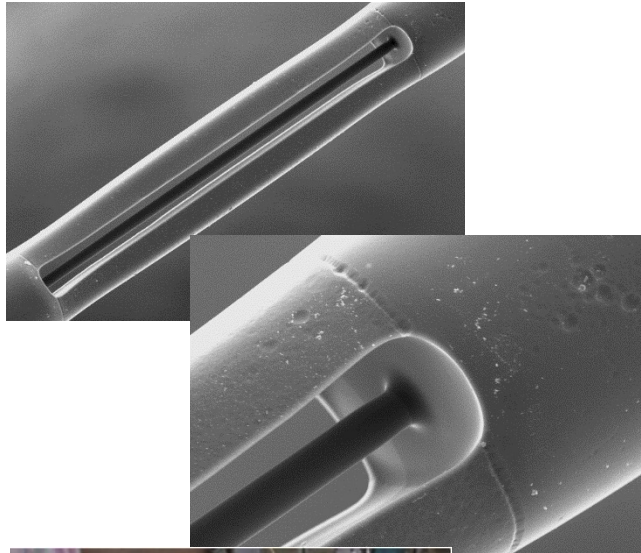

## Chemical, biological & biomedical sensors (Pedro Jorge)

- ✓ Optical fiber evanescent sensors
- ✓ Fluorescence/Colorimetric dyes
- ✓ Spectroscopy
- ✓ Sol-gel, photopolymers, chemical sensitive polymers, nanomaterials

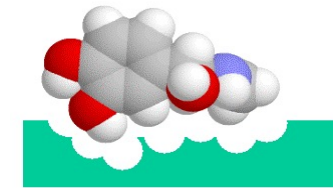

First order grating: point-by-point writing

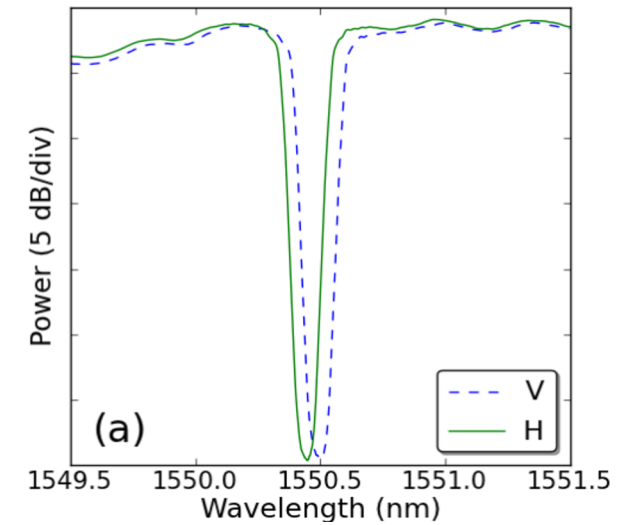

# Photonic sensors

## Sensing heads & Interrogation schemes

- Advanced optical spectroscopy (UV-VIS, NIR, +AI)
- Sensing nanomaterials: SPR, SERS, molecular imprinting

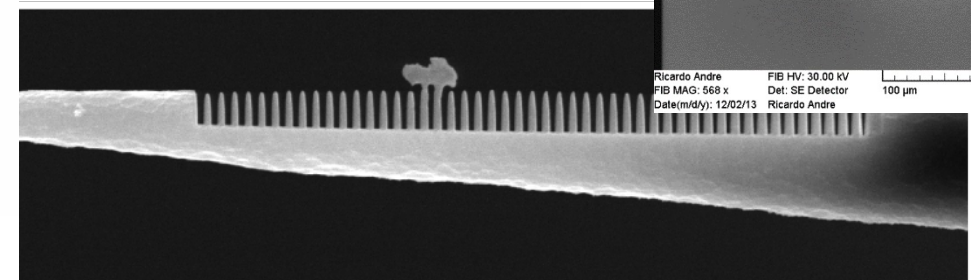
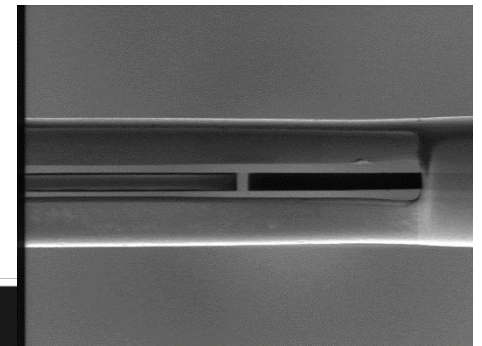
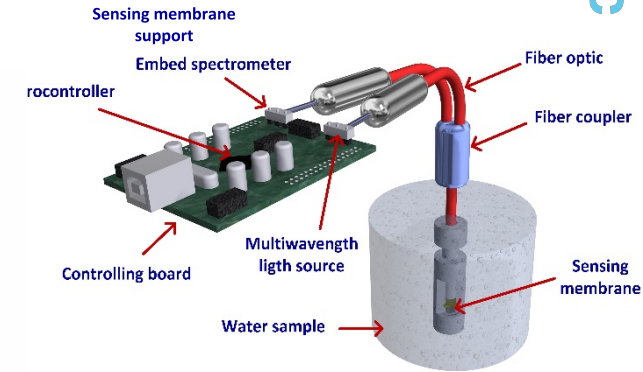
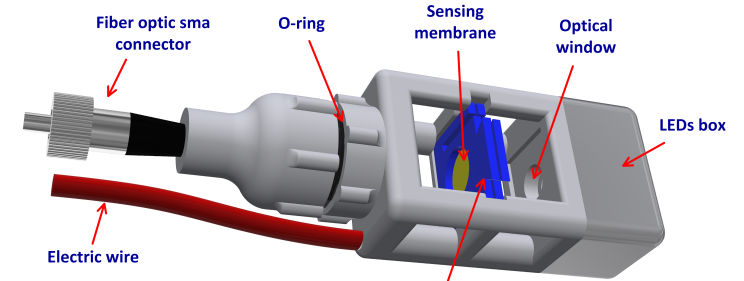
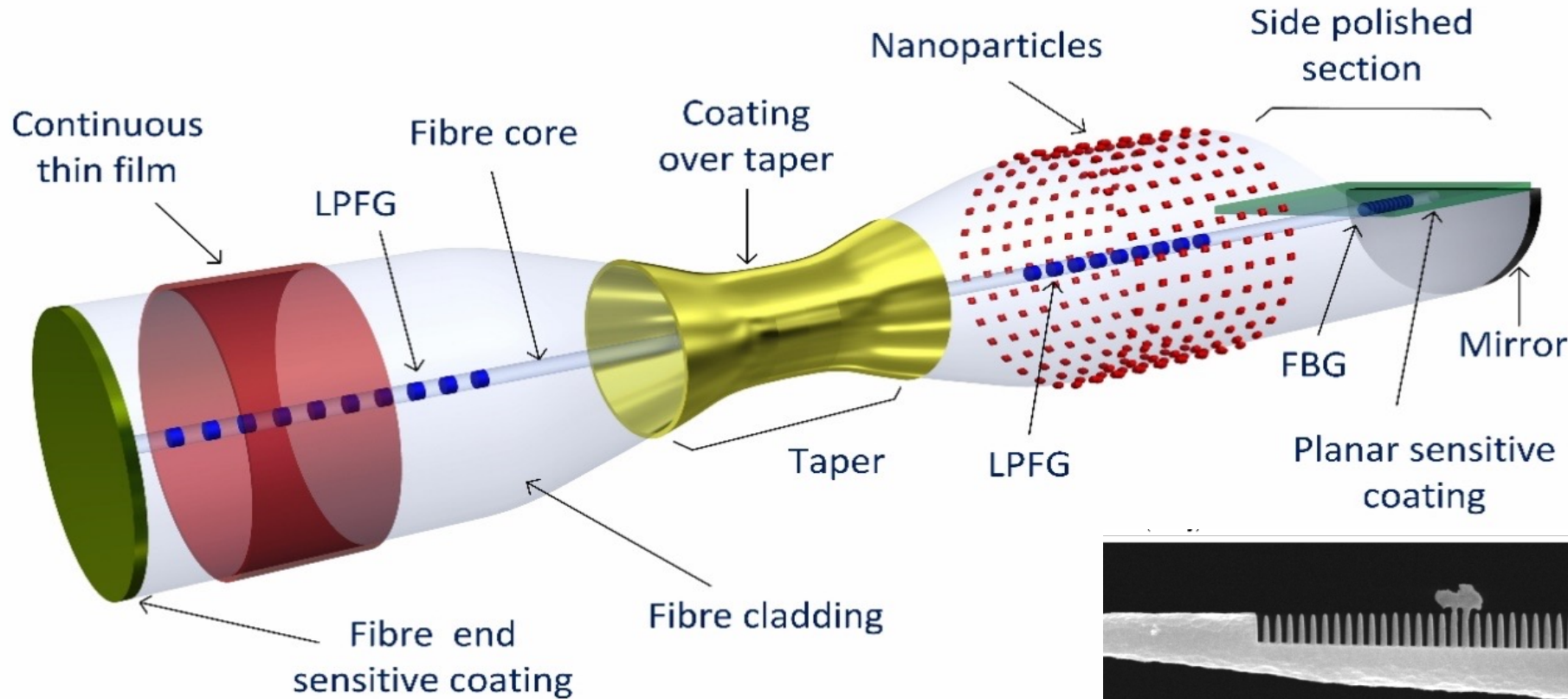

# Example: Thrombin detection

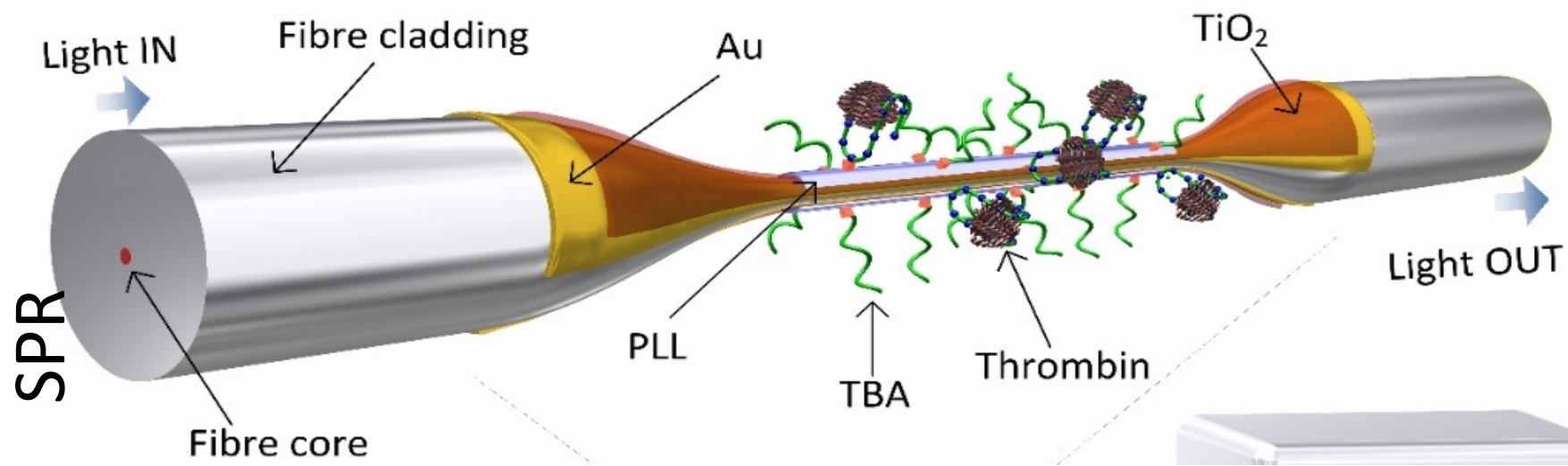
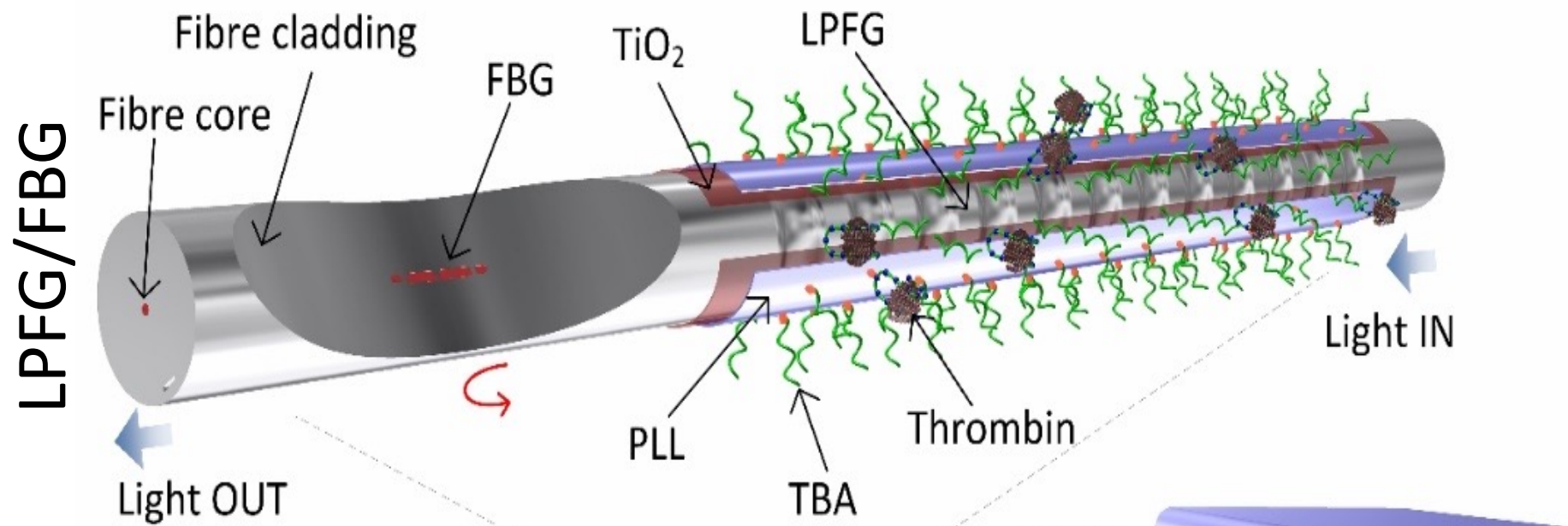

# OPTICAL FIBER TWEEZERS – APPLICATIONS

## Self assembly of micro lenses by guide Photo-Polymerization

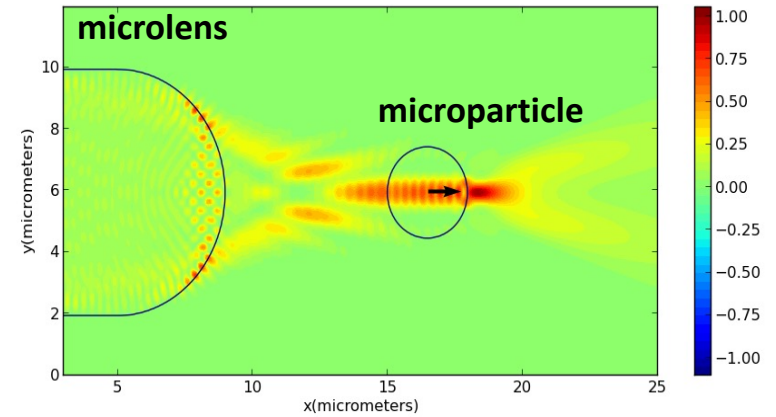
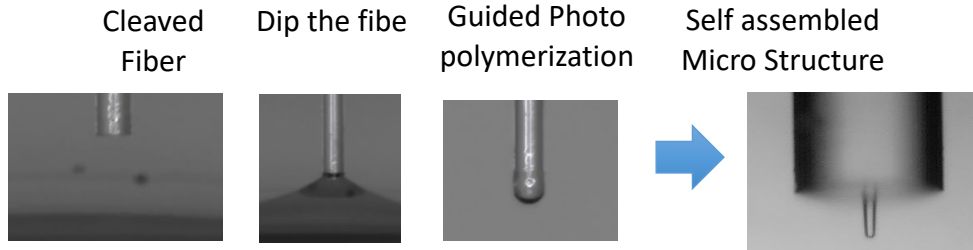

FIB machined fibers: modulation with structured patterns introducing focusing, trapping and twisting ability with light.

## Optical fiber with a Fresnel zone lens (FIB):

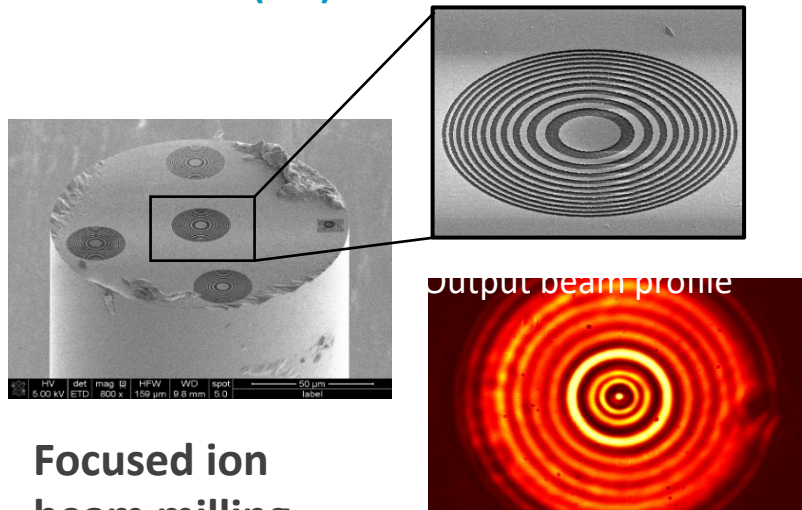

- Focused ion beam milling

## Optical fiber with a spiral phase lens (FIB):

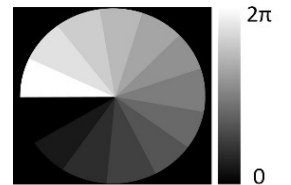
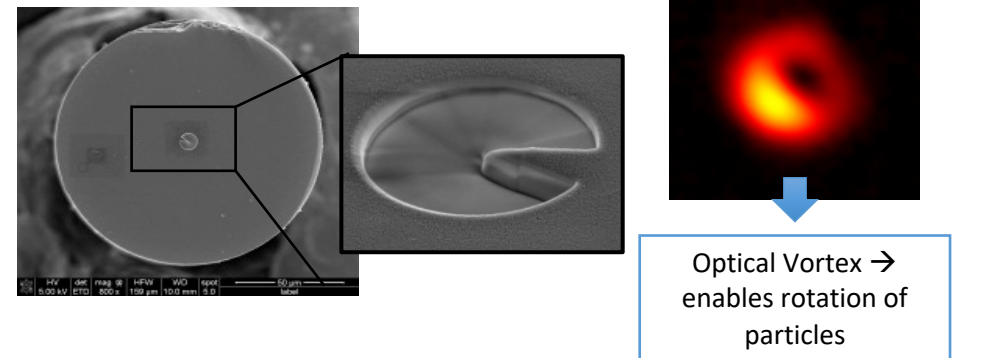

# Laser Induced Breakdown Spectroscopy (LIBS)

Elements and Chemical Structure identification and quantification

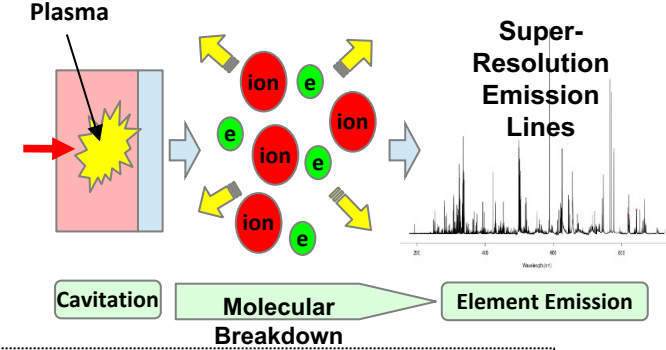

## Geology and Raw Materials

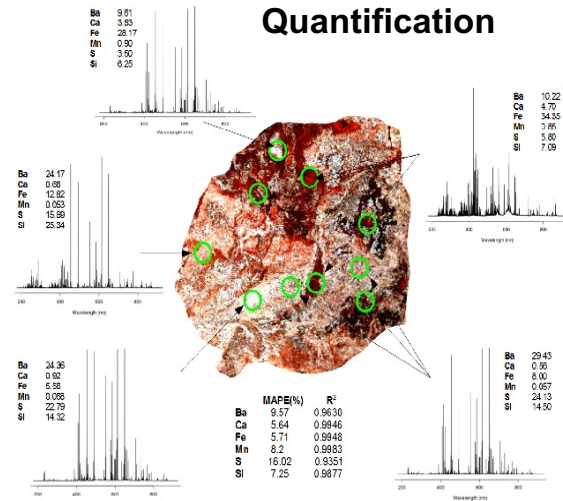

## Human and Veterinary Medicine

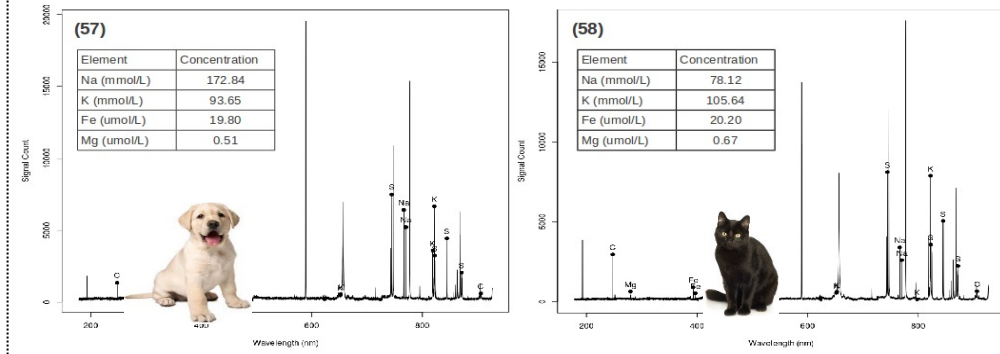

## Blood and Tissue Analysis

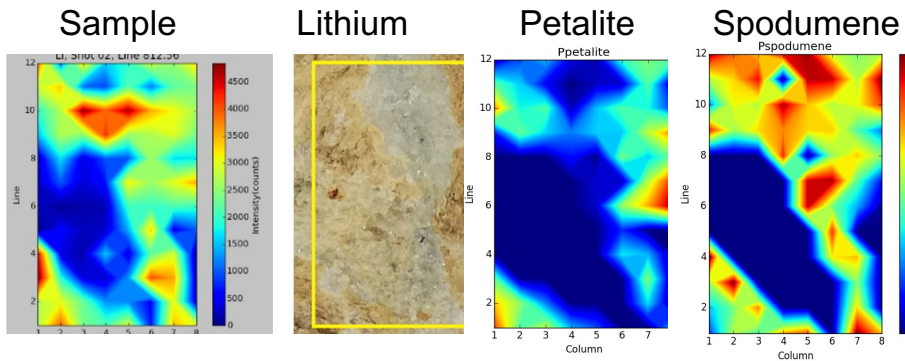

## LIBS Imaging

## Industry

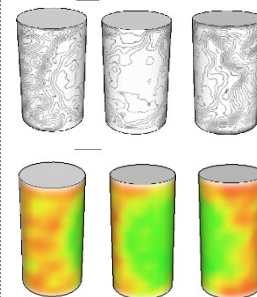

## Coatings

## Agriculture



## Plant and Soil Composition

# OCT: optical coherence tomography (OCT)

## 3D contactless, non invasive bio-imaging

- chick embryos
- skin
- wood, cork
- contrast enhanced

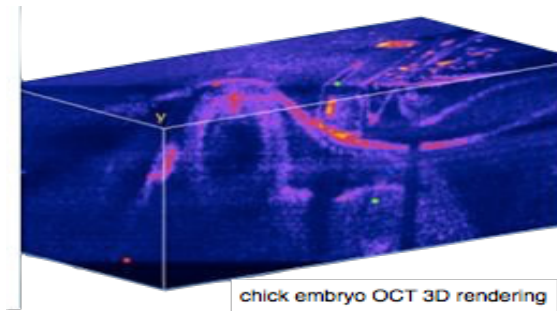

# Advanced Optical Imaging

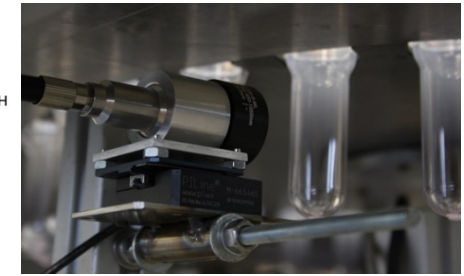
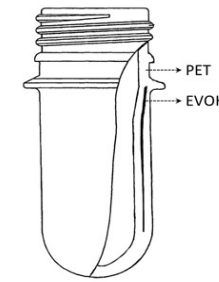
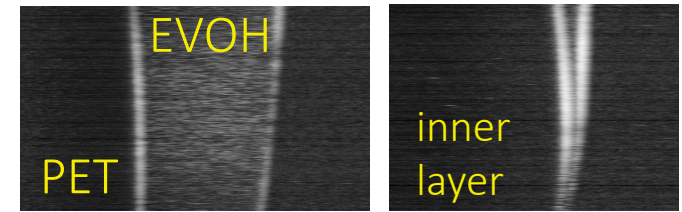

## non destructive inspection:

- PET preforms
- glass vials
- microfluidics chips

## compressive sensing for LIDAR & holographic single fiber imaging

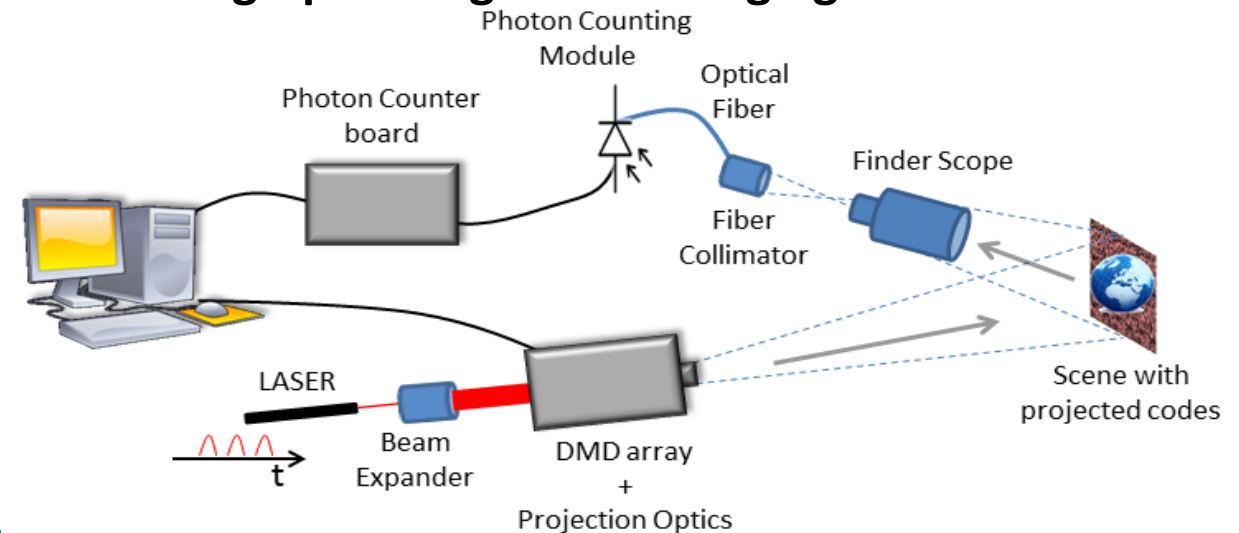
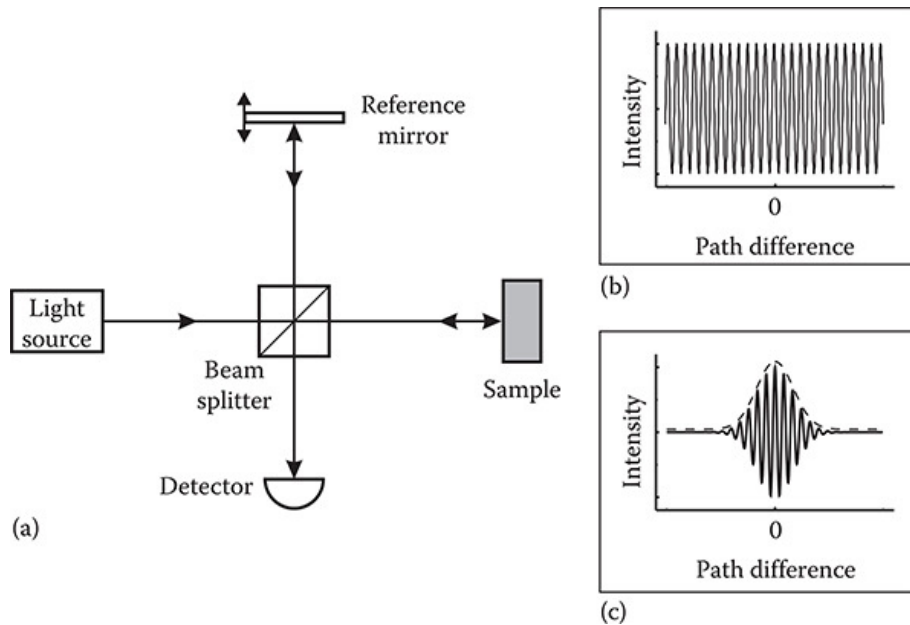

# Quantum Optical Engineering

***Mission: Develop new competences, know-how and tools in quantum hardware based on light, bridging Fundamental Science to Applications, to support Quantum Technologies.***

## **METAMATERIALS FOR SENSING**

Develop nanostructured optical metamaterials that can sense hydrogen and electromagnetic fields for green technologies

## **SINGLE PHOTON TECH**

Exploratory research to develop experimental skills in single photon generation, manipulation and detection

## **NANOPHOTONICS FOR QUANTUM SENSING**

Design and optimize nanostructured optical fiber sensors

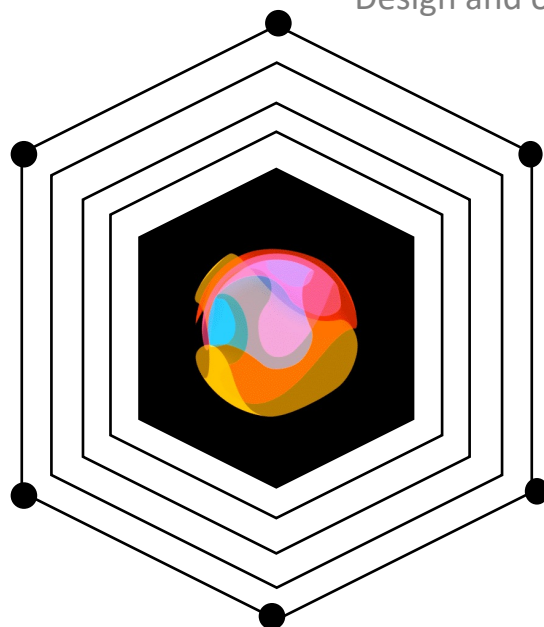

## **ANALOGUE QUANTUM COMPUTING AND SIMULATION**

Study fluids of light (in nonlinear nonlocal media) as a platform quantum simulation and neuromorphic and analogue computing. This technology can be integrated in optical sensors fast and low energy processing of data.

## **HPC DIGITAL TWINS OF COMPLEX QUANTUM and PHOTONIC SYSTEMS**

Develop numerical models of complex quantum systems such as quantum gases

## **HPC TOOLS FOR SENSOR FUSION**

Efficient and scalable ray-tracing engines combined with Bayesian Machine Learning for tomographic reconstruction and sensor fusion

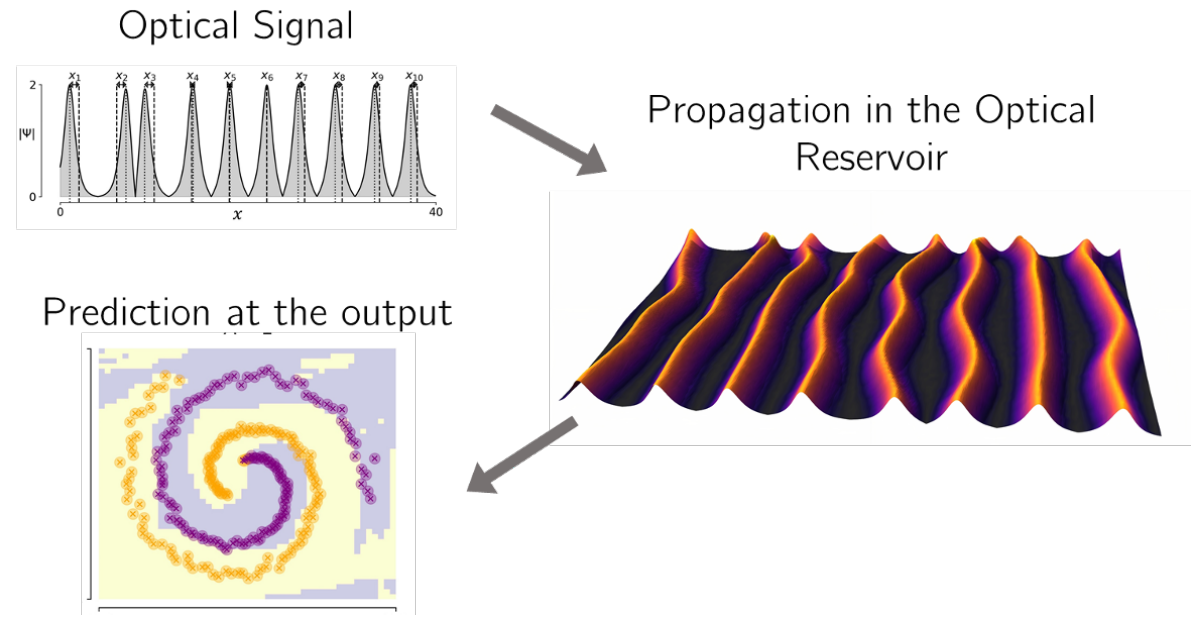
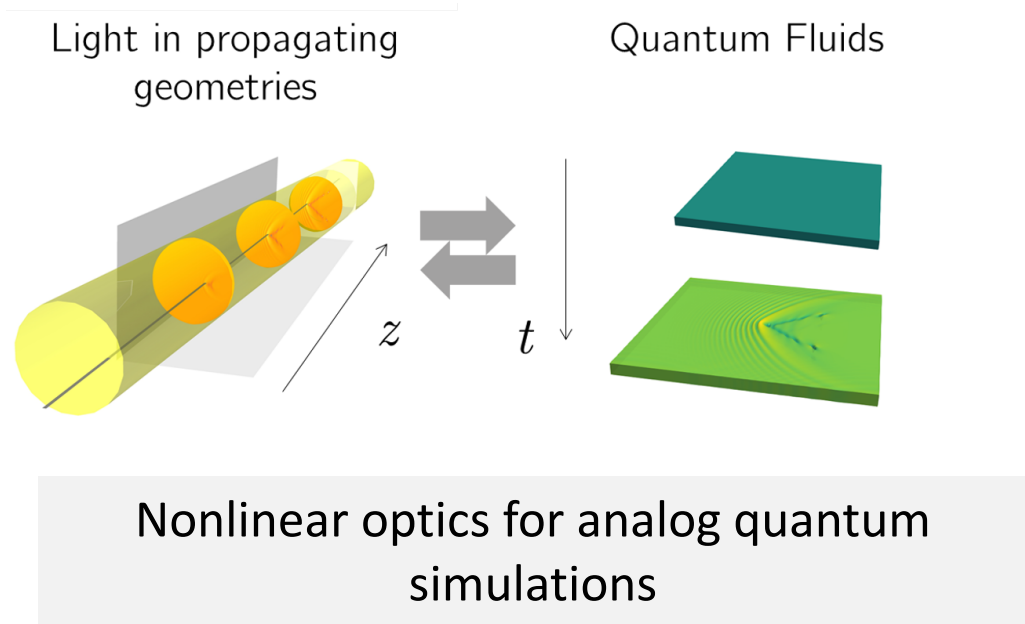

- Explore the use of nonlinear optical systems for the development and deployment of analog quantum simulation platforms
- Research on reservoir computing solutions for the implementation of all-optical information processing devices, aiming for a seamless integration with the various optical sensing devices

# Advanced Sensing technologies

## Quantum Plasmonics to Optical Metamaterials

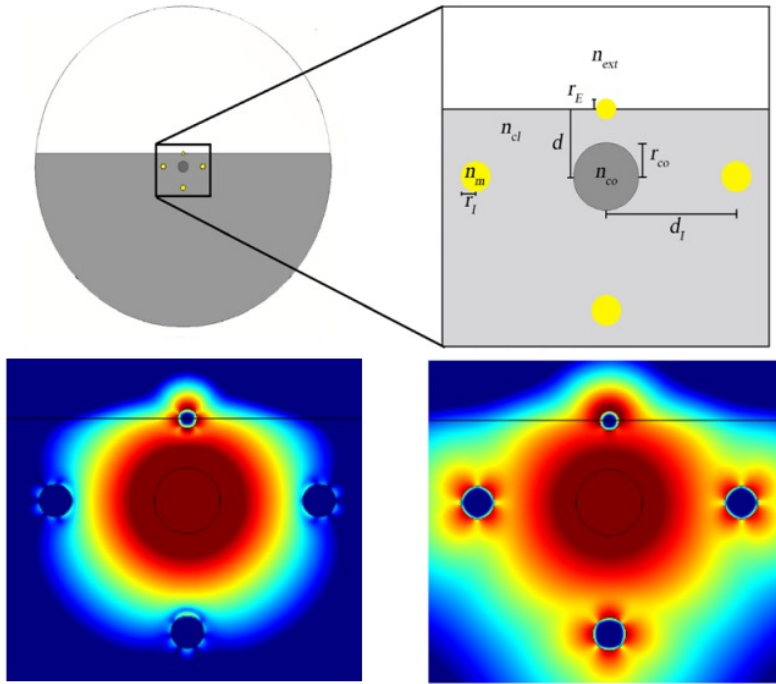

Design for a nanoplasmic sensor of refractive index and temperature without cross-talk.

New technology of high performance sensors based on optical metamaterials

Design and engineering of optical sensors that explore the quantization and interaction of plasmonic mode in nanostructured optical fibers.

Metamaterial sensor of hydrogen

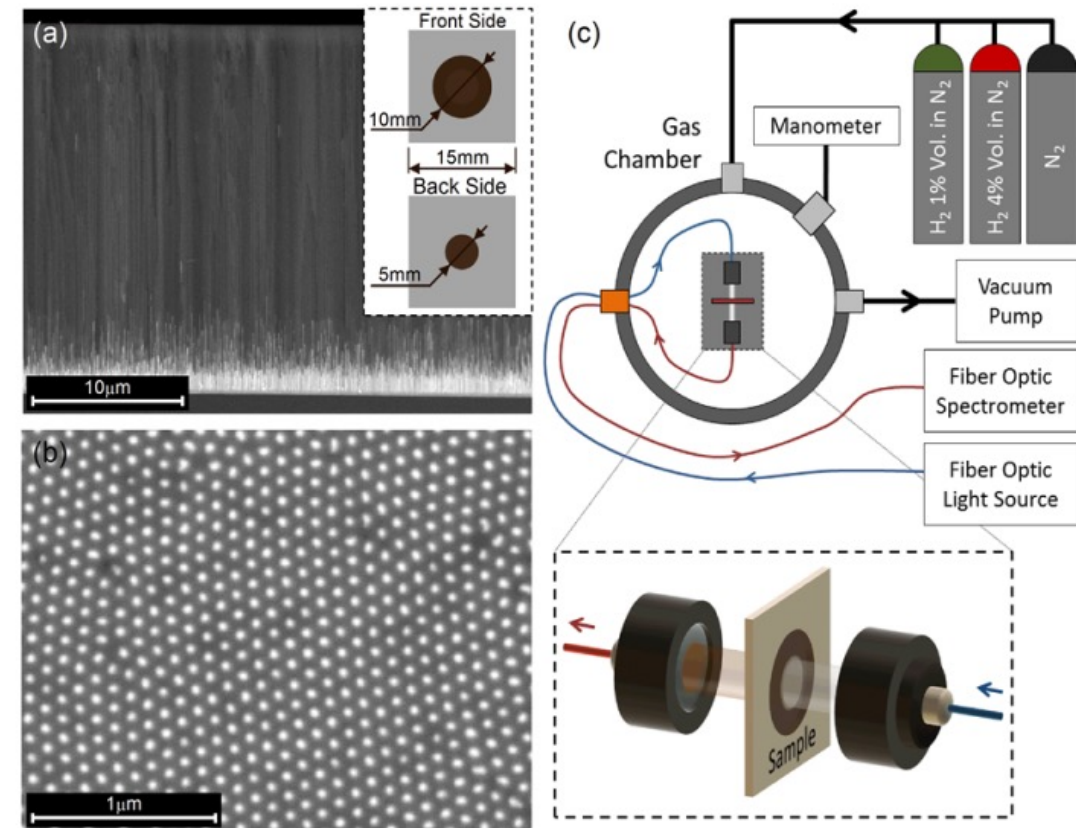

# Integrated Optics and Microfabrication

- Optofluidics & microfluidics
- Lab on a fiber & Lab on a chip
- Integrated optics
- Generic microfabrication & machining
  - Glass
  - Polymers

## Femtosecond laser writing

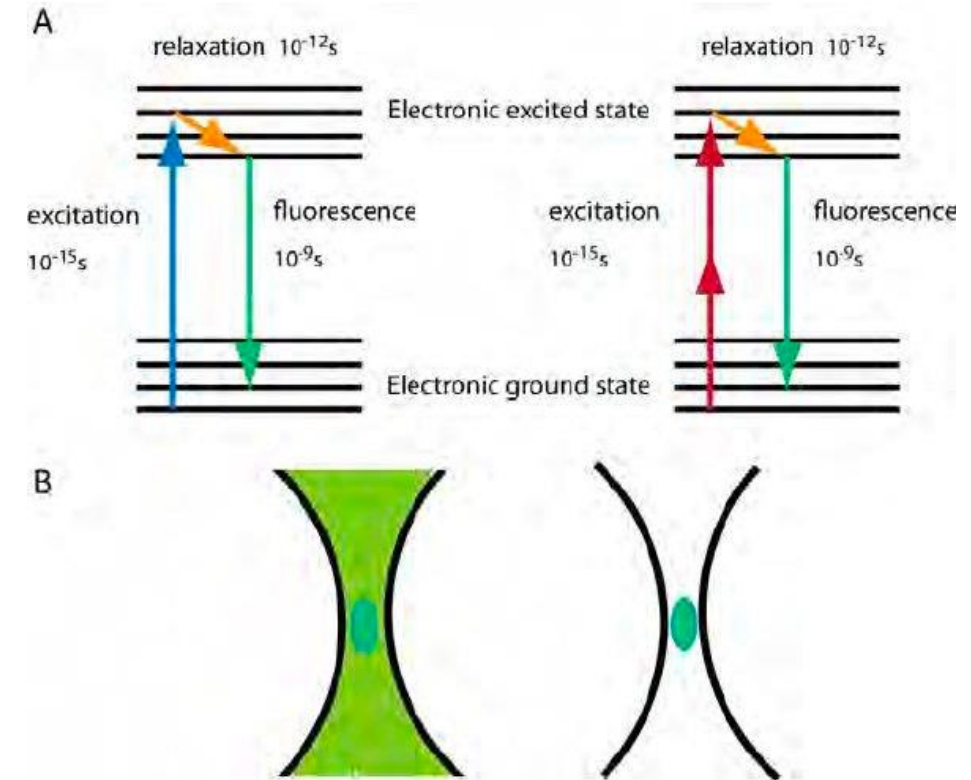

Linear vs non-linear absorption

# Integrated optics waveguides and machining

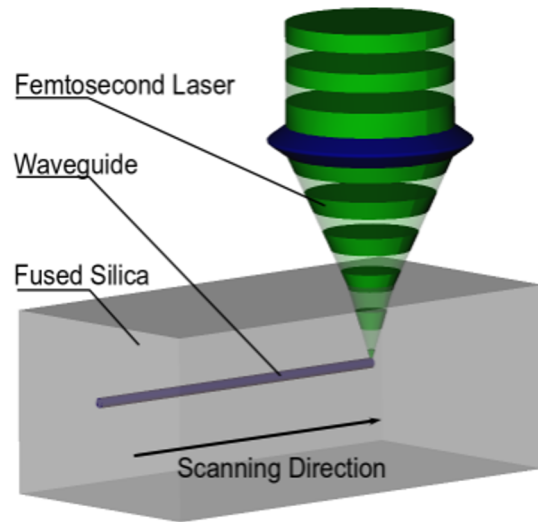

- Subwavelength resolution
- 3D fabrication

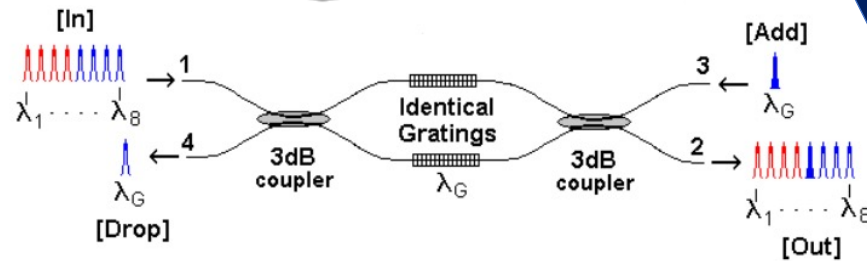
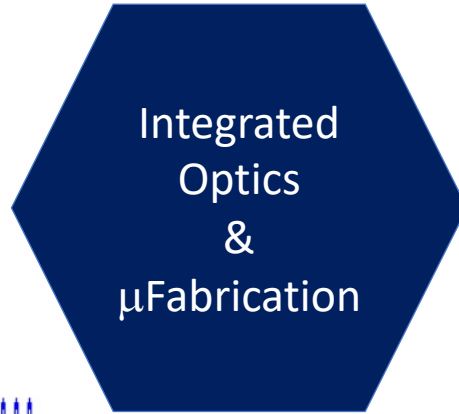

## Nanostructures by photopolymerization

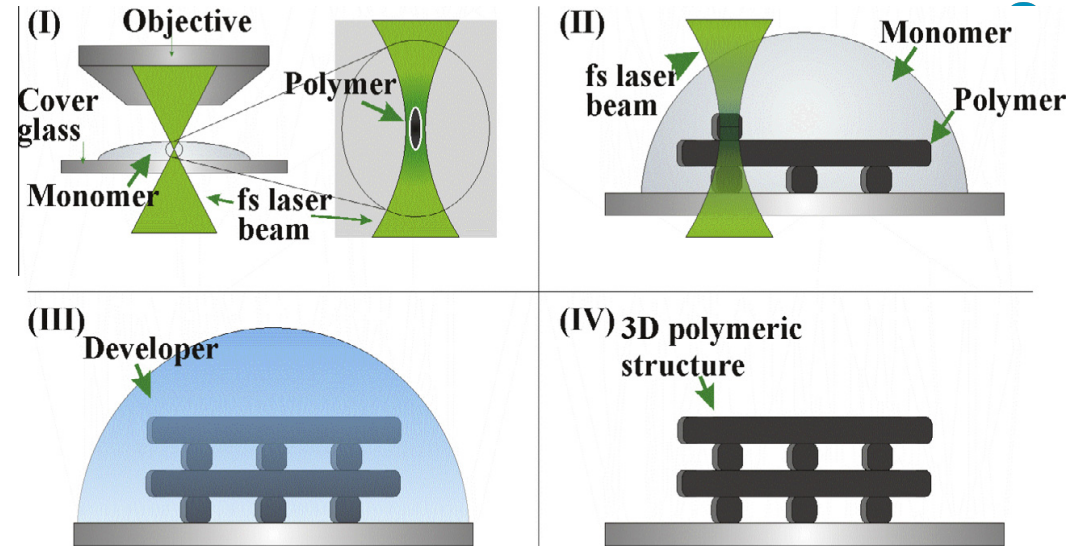
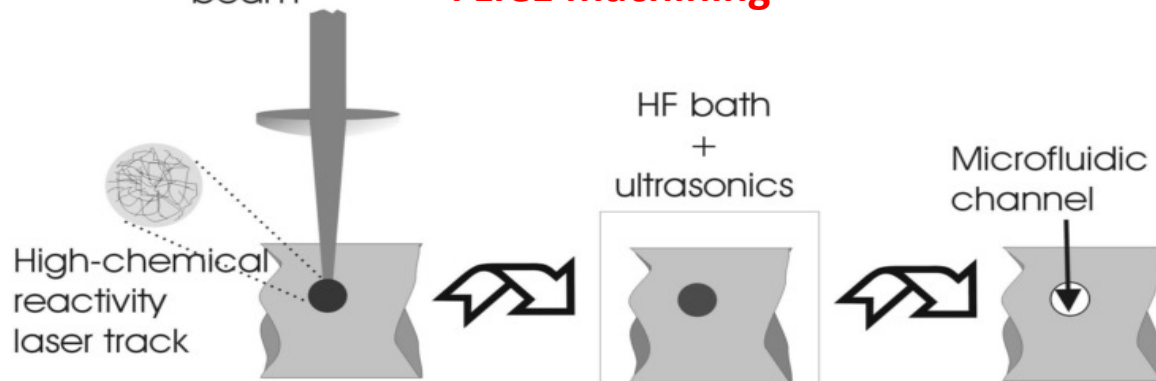

Fig. 3. DLW experimental procedure (I) beam focusing (II) laser writing (III) development (IV) completed structure

Femtosecond writing beam

## FLICE machining



## 3D machining



# Microfabrication examples

## Multiphoton Photopolymerization

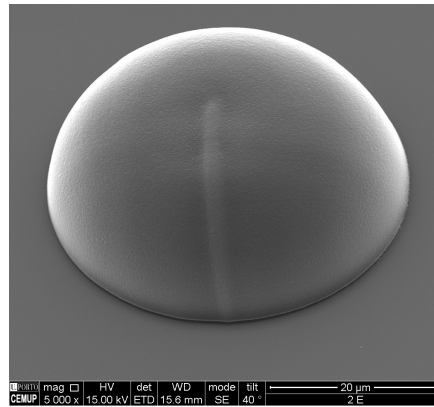
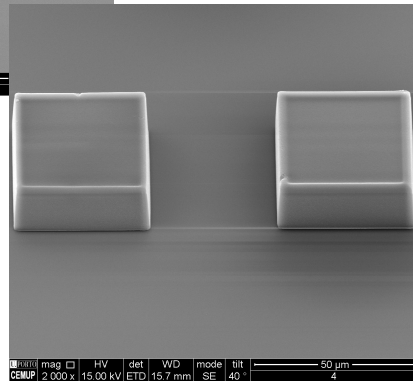
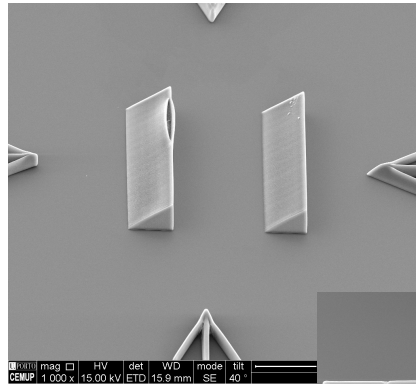
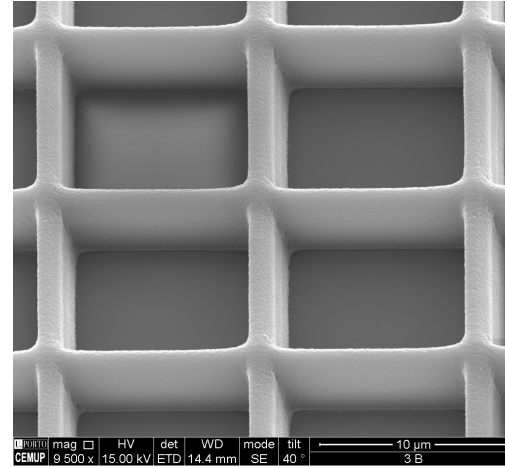
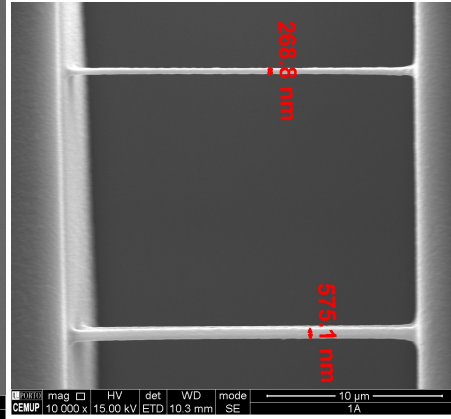
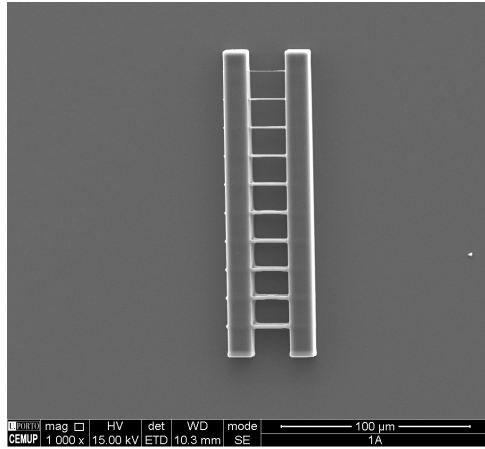

height = 40 μm    height = 50 μm

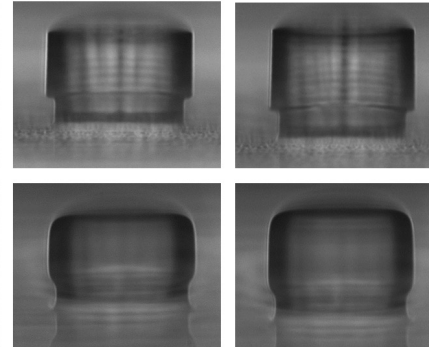

## Fused silica micromachining/etching

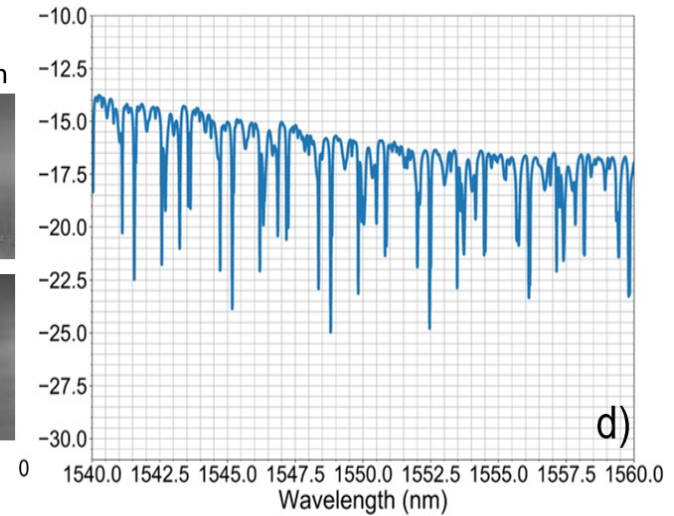
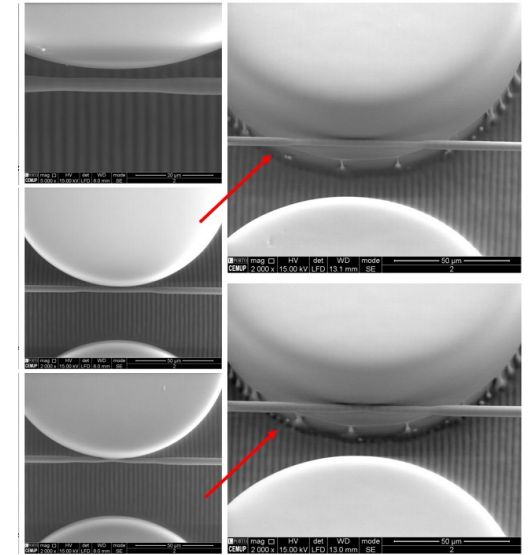
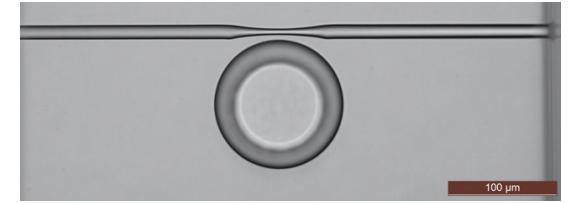

# CAP - TEAM AND ACTIVITY

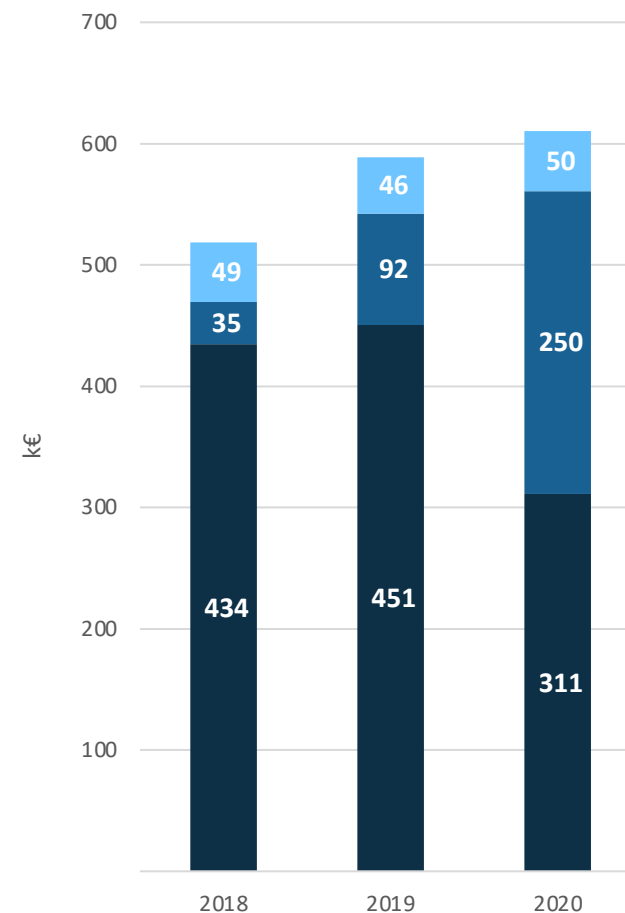
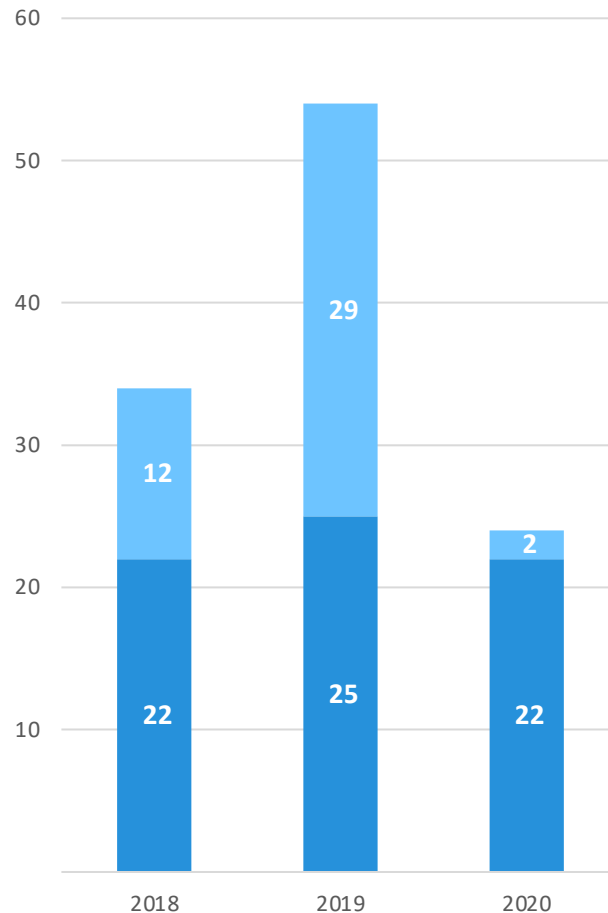
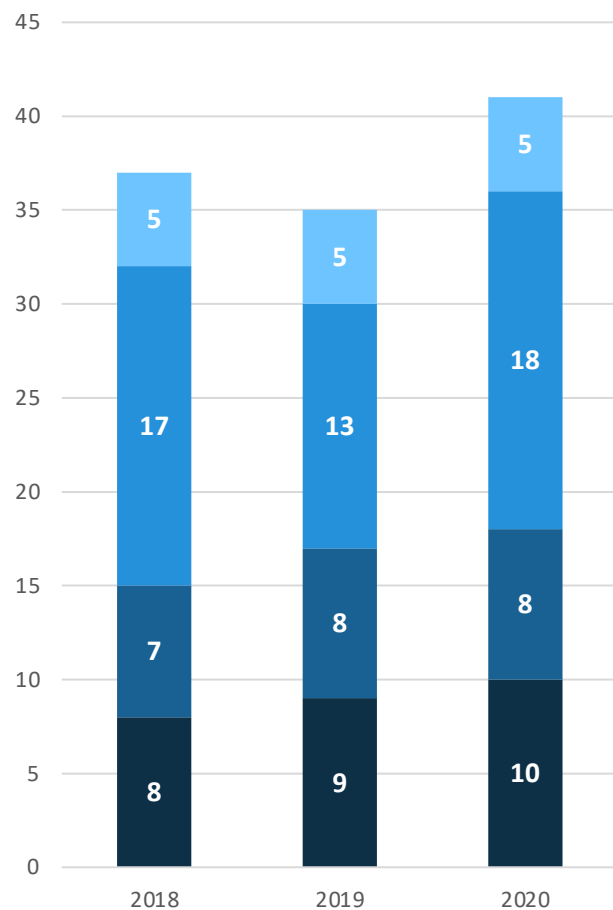

R&D Employees
  Academic Staff  
 Grant Holders and Trainees
  Affiliated Researchers

Indexed Journals
  Indexed Conferences  
 Books
  Book Chapters

R&D Services and Consulting  
 EU Programmes  
 National Cooperation Programmes with Industry  
 National R&D Programmes

## OBJECTIVES AND THEIR ACHIEVEMENT IN 2021

- Good balance between more fundamental research and development of high TRL's solutions; ●●
- Recruitment of MSc and PhD students; ●
- Internationalisation - increase the number of European collaborations and projects, involvement in international bodies; ●●
- Increase CAP researchers' awareness for potential opportunities for IP protection; ●●
- Increase the number of technology transfer projects with local and international industry. ●●

# INNOVATION ACTIVITIES/MAIN MARKETS AND APPLICATION AREAS

	TEC4AGRO	TEC4ENERGY	TEC4HEALTH	TEC4 INDUSTRY	TEC4SEA	Other
<b>Electronics and photonics Integration</b>						
Electronics PCB design, implementation, teste and characterization	X		X		X	
Micro and nanofabrication techniques			X		X	
Optoelectronics assembly and packaging	X		X			
Photonic systems implementation, test and characterization	X		X		X	

# MAIN EXTERNAL PARTNERS AND COLLABORATIONS WITH OTHER CENTRES – RESEARCH & INNOVATION

RESEARCH

INNOVATION

	CRAS	CRIIS	CBER	CTM	
	<ul style="list-style-type: none"> <li>INSITE</li> <li>TEC4-SEA</li> <li>ESAPlastics</li> </ul>	<ul style="list-style-type: none"> <li>METBOTS</li> <li>AGRINUPES</li> <li>SMARTFARM</li> <li>MyNPK*</li> <li>SpecTOM</li> </ul>		<ul style="list-style-type: none"> <li>TEC4-SEA</li> <li>Graphenna*</li> </ul>	
	<ul style="list-style-type: none"> <li>INSITE</li> </ul>	<ul style="list-style-type: none"> <li>AGRINUPES</li> <li>SMARTFARM</li> <li>MyNPK*</li> </ul>	<ul style="list-style-type: none"> <li>iLoF</li> </ul>		
	EGITRON	IloF	Microprocessador - Sistemas Digitais, S.A	ESA	
	<ul style="list-style-type: none"> <li>CORKSURF</li> </ul>	<ul style="list-style-type: none"> <li>Consultancy</li> </ul>	<ul style="list-style-type: none"> <li>Led</li> </ul>	<ul style="list-style-type: none"> <li>Lira</li> </ul>	

INTERNAL

EXTERNAL

\*Seed projects

# EUROPEAN PROJECTS

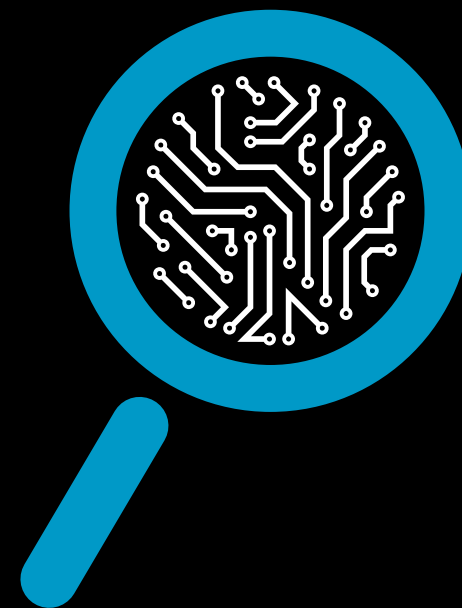

Supported by: Connecting matters

LIDER

FUNDS INESC/global: 425k€/1,5M€

INSITE goal is to develop new smart LIBS tools, suitable for field operation in the mining industry, having reliable analytical performance, capable of guiding decisions in exploration and exploitation scenarios.

## SMART LIBS Prototypes

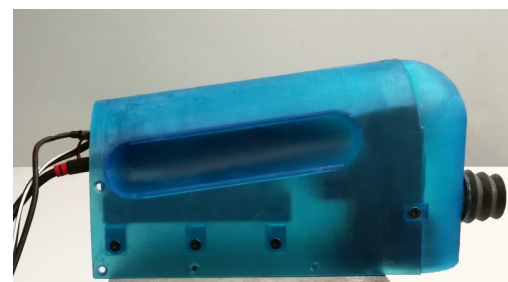

Centres: CAP and CRAS

Technology: Software and Robotics

Relevance:

- Strategic partnership for future EU proposals
- Good perspectives for Tech Transfer ( Licensing to LSA)

## SMART LIBS Software



## SMART LIBS Database

Material Name	LIBS Data	Image
Sample 1	[LIBS Spectrum]	
Sample 2	[LIBS Spectrum]	

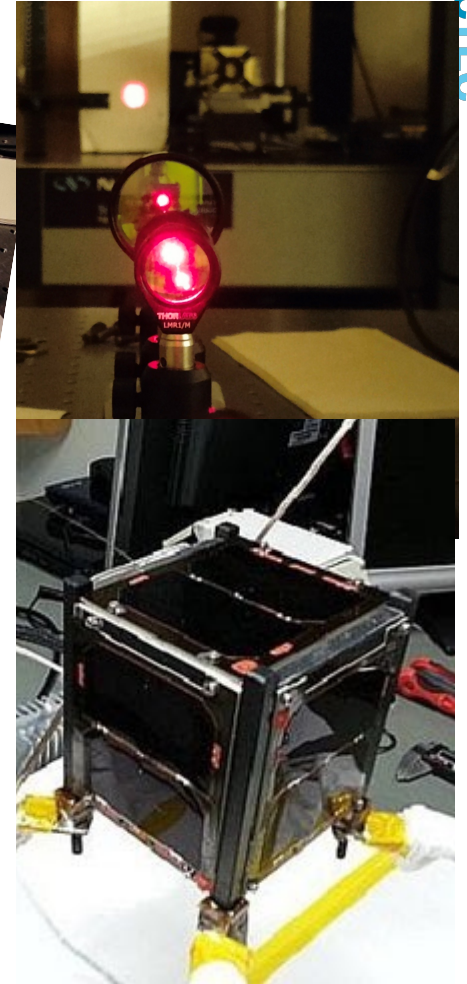
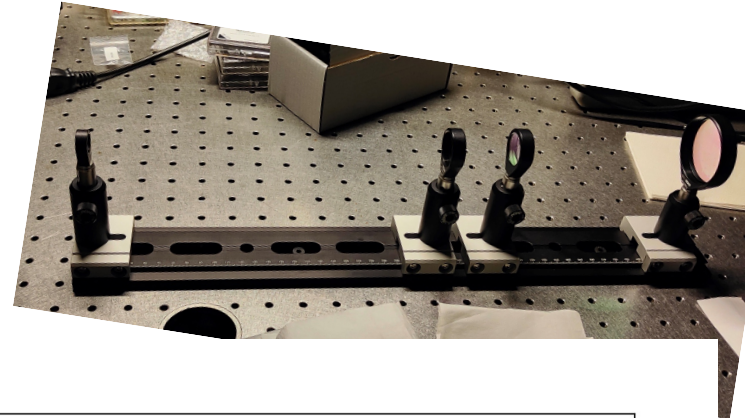
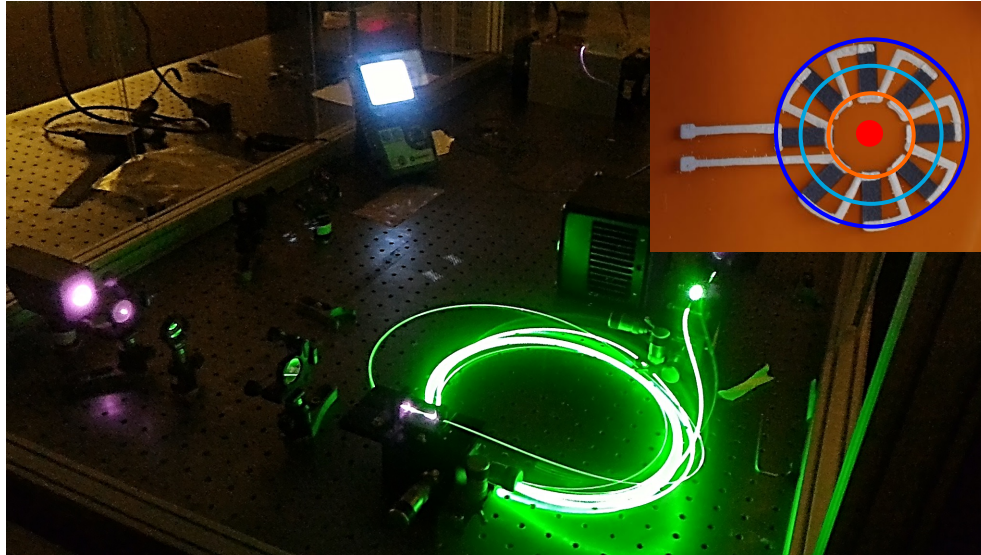

- High power fibre Erbium doped fibre
- 22% Efficiency
- Wavelength@1550 nm and 80 W Output Power
- Telescopes 100 m – 2000 m

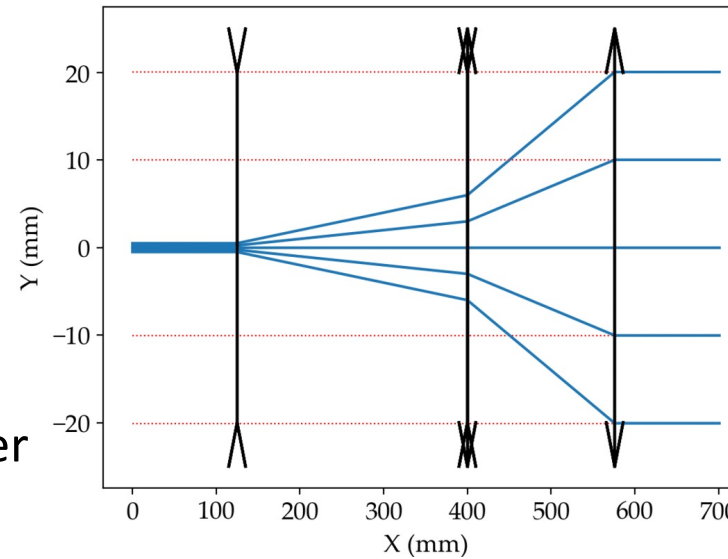

3U CubeSat 30x10x10cm

**EU PROJECT, FCT FUNDED**  
**(M-ERA.NET)**

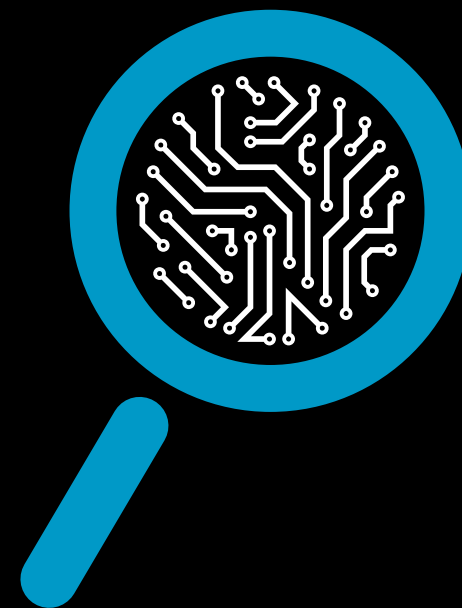

# Biosensors Research Line: CORK SURF PT2020 2021-2023

Programme co-funded by the EUROPEAN UNION  
 M-era.Net  
 PHOTONIC SENSING  
 FUNDS INESC/global: 146k€/0.73M€  
 Leader  
 IFAC  
 UNIVERSITÀ DEGLI STUDI FIRENZE  
**INESCTEC**  
 UNIVERSITÀ DI PISA  
 WEST Systems  
 Scope Fluidics  
 IChF Instytut Chemii Fizycznej PAN

SAFEWATER goal is to develop new highly sensitive microsensors for the detection of emerging microcontaminants in water, using microresonators and advanced interrogation systems.

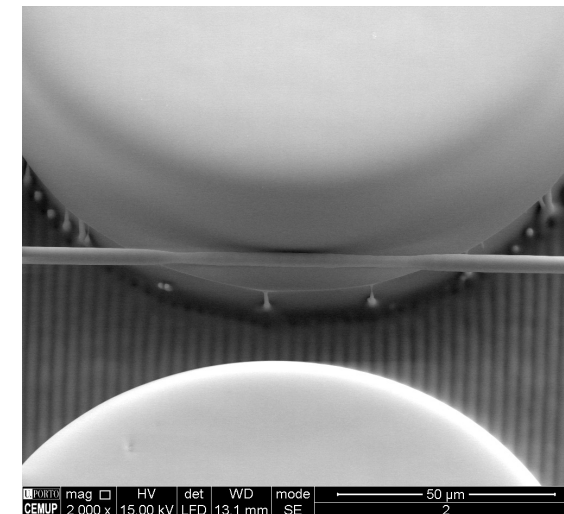

Centres: CAP

Technology: MicroOptics and Optoelectronics

Relevance:

- Strategic partnership (EU)
- Seed for further innovative projects

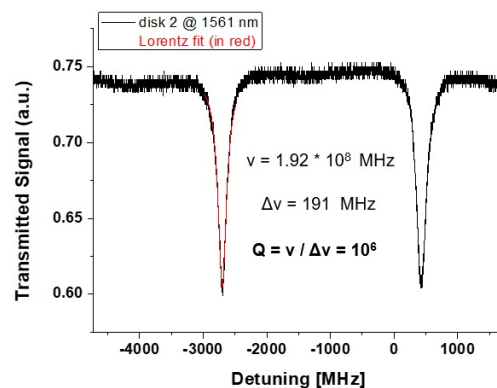

# R&D CONTRACTS

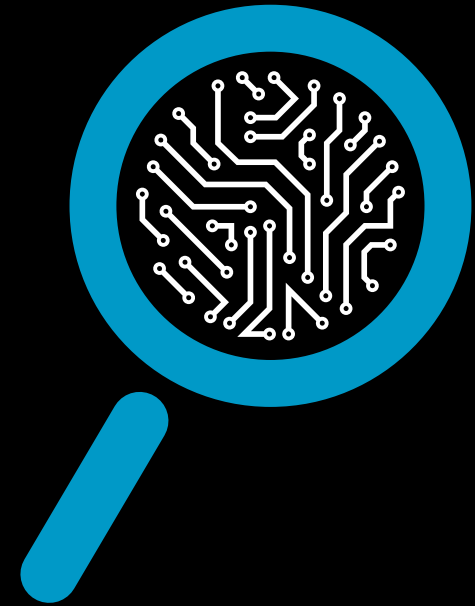

# DFOS REN – Distributed Fibre Optic Sensing for collision detection on MAT lines

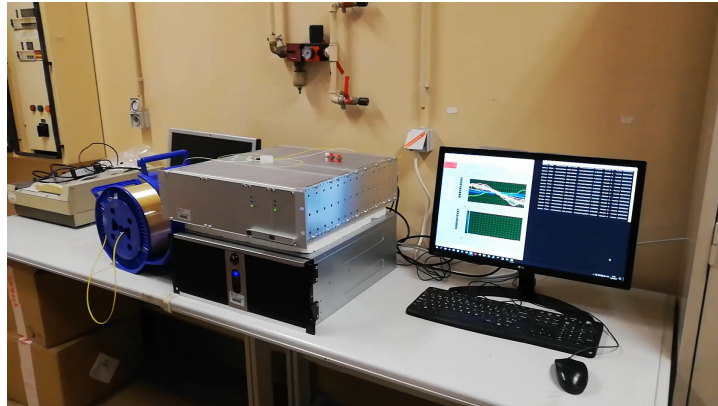

52 k€

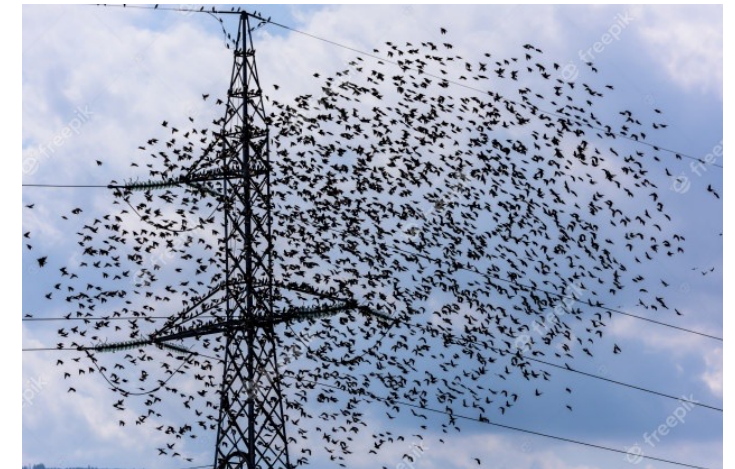
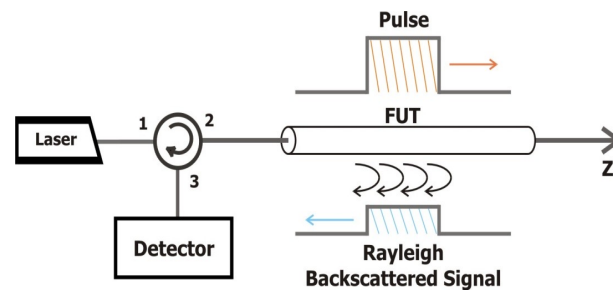
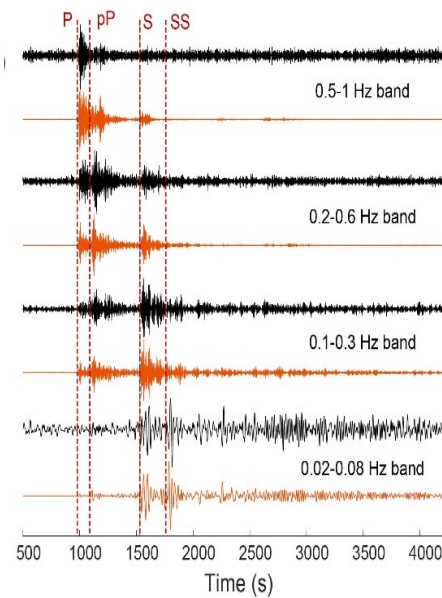
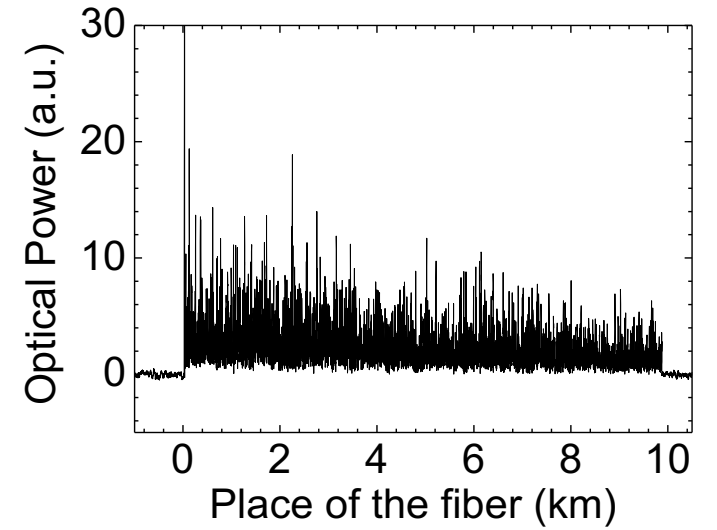
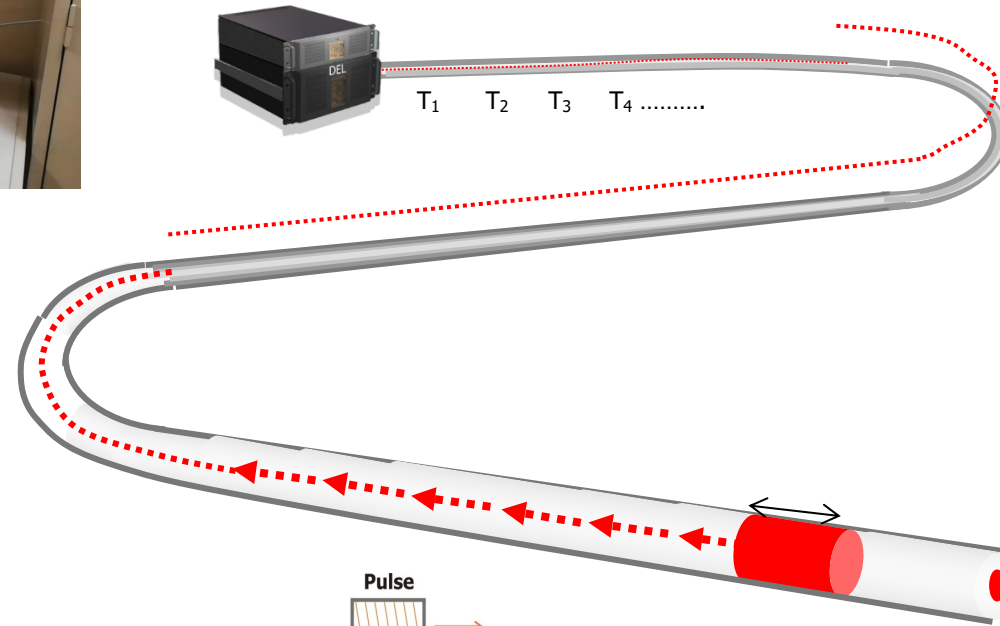

# LED PROJECT

DMS - Displays & Mobility Solutions, Lda

54 k€

- The Sun reflection can reduce visibility of the information on some occasions. **New normative impose restrictions on new panels reflection (mainly with the Sun 5 to 10 degrees over the horizon)**
- This project had the focus on the design of acrylic light pipe connecting the three-color LED to the panel surface to reduce the level of the reflected light bellow the normative.

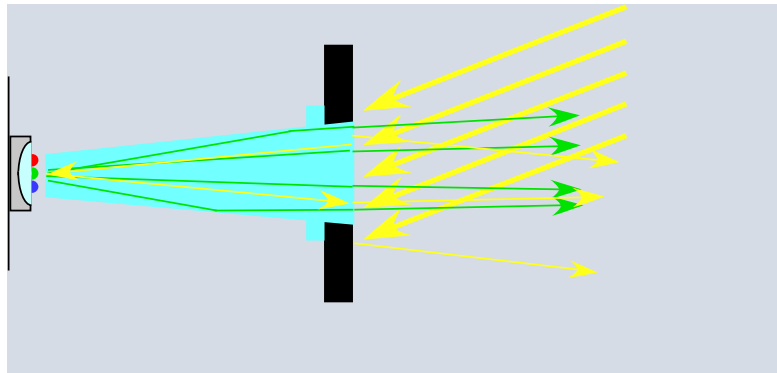

**Technology:** Optical systems design

**Relevance:** Demonstration of optical design capabilities in non-imaging optical systems



**PANELS PASS EXTERNAL TESTS AND ARE ON PRODUCTION!**



# LIRA- OPTICAL FIBER MICRO-KELVIN TEMPERATURE SENSOR NETWORK FOR SENSITIVE OPTICAL PAYLOADS

ESA / INSTITUT D'ESTUDIS ESPACIALS DE CATALUNYA, 100k€

Launch in 2034

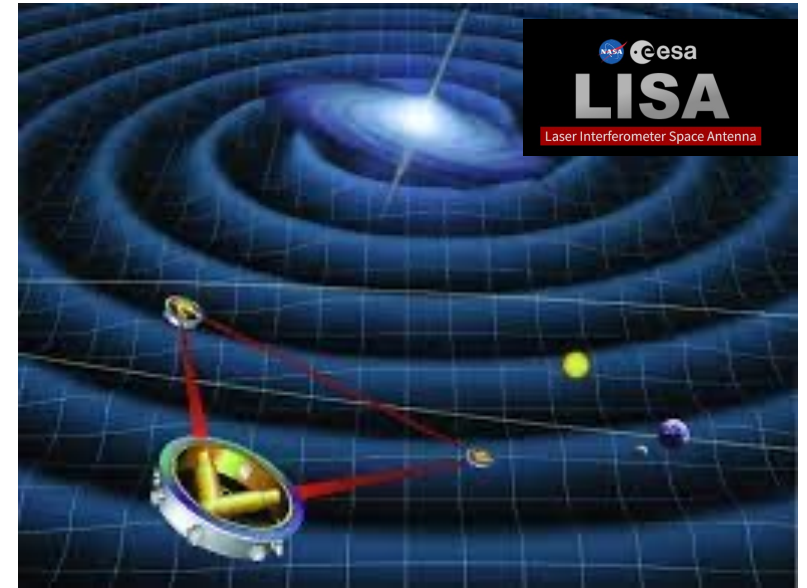
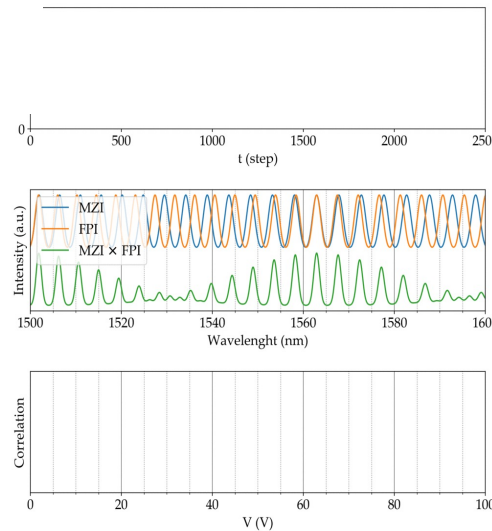
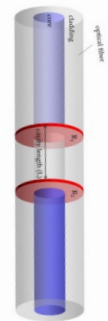
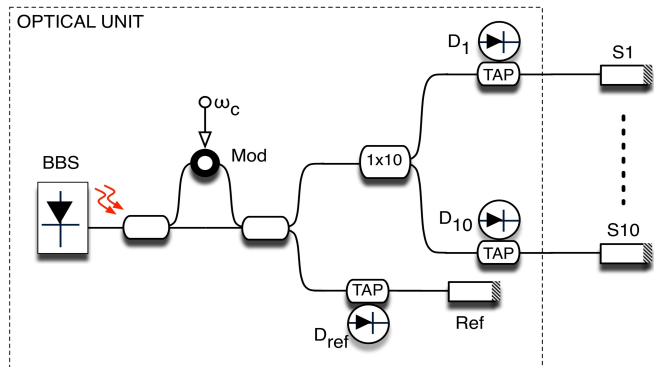
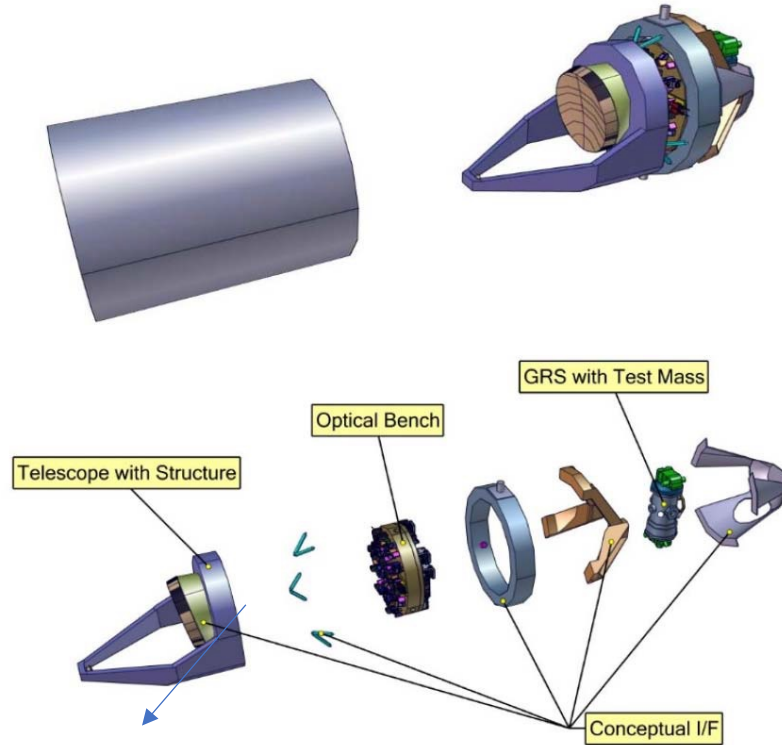

## Functional Requirements

### Req.Fun.1 Number of sensors

The Elegant Breadboard Model shall allow temperature measurement at **10 independent locations**

### Req.Fun.2 Absolute Measurement Accuracy

The Elegant Breadboard shall be capable of measuring absolute temperature with an accuracy of **0.1K**

### Req.Fun.3 Measurement of Temperature Variation

The Elegant Breadboard shall allow the measurement of temperature variations with **10<sup>-6</sup>K**

# TECHNOLOGY TRANSFER

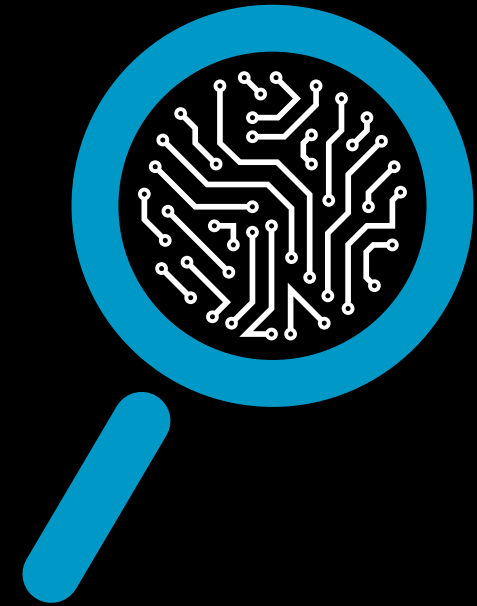

# LIBS Research Line: CORK SURF PT2020 2021-2023



FUNDS INESC/global:  
400k€/1M€

Leader and Technology Taker



Azevedos Indústria  
@azevedos.industria · Industrial company

CORK SURF goal is to develop new tool for process control in cork industry. LIBS technology is being explored for real time assessment of quality control (homogeneity and thickness) of functional coatings in cork.

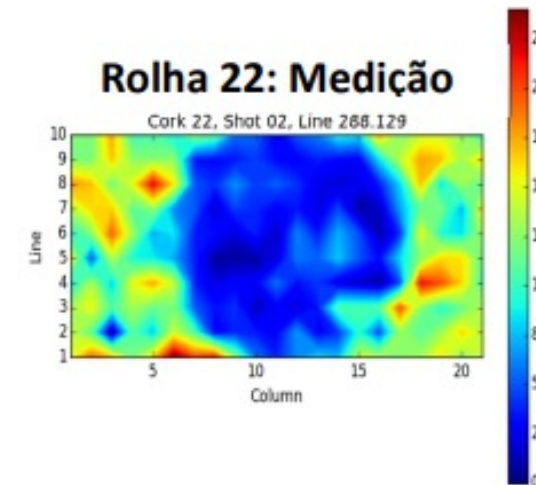
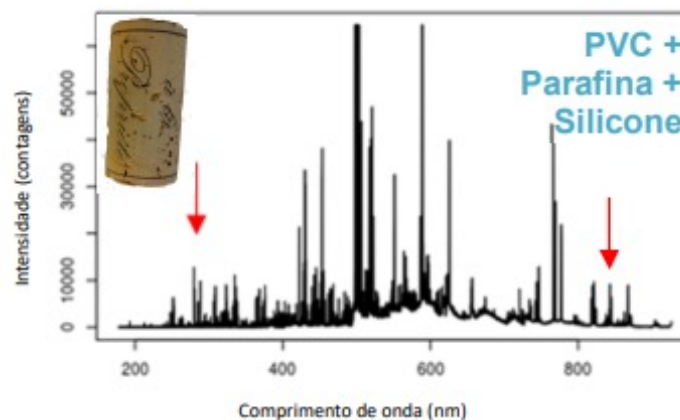

Centres: CAP

Technology: LIBS system and software

Relevance:

- Licencing Oportunity (Patent under evaluation)
- Increasing competitiveness of Portuguese Industry

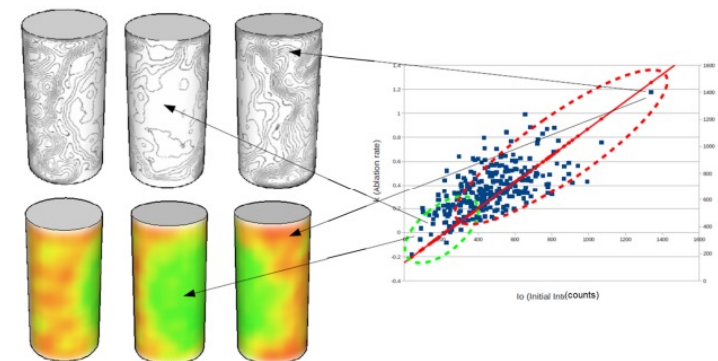

# SEED PROJECTS

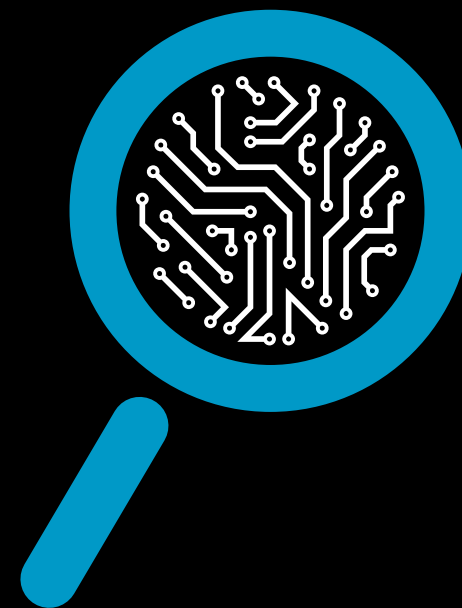

# • Food4You - Real-time monitoring of fresh food quality with optical sensors

## MAIN OBJECTIVES

Development and optimization of an optical sensor based on luminescent spectroscopy to detect food born biogenic amines using a sensing pellet with high sensing specificity to different biogenic amines related to food deterioration.

## SENSING MEMBRANE FABRICATION

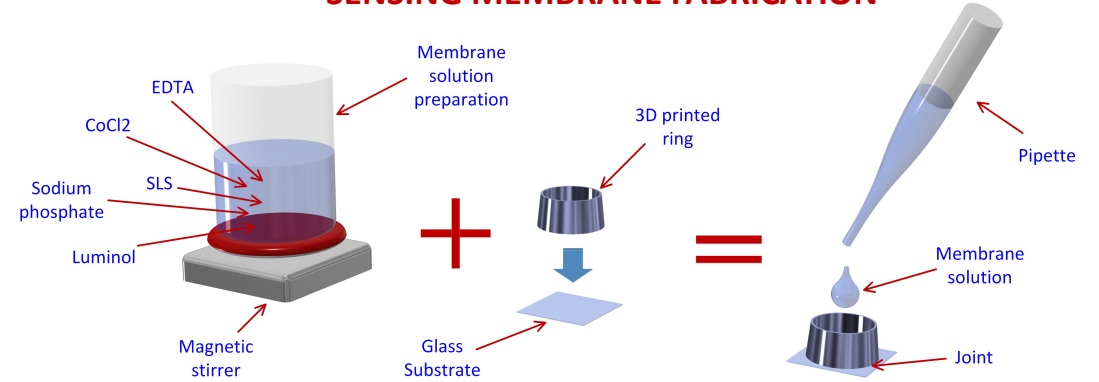

## SPECTROMETER SYSTEM

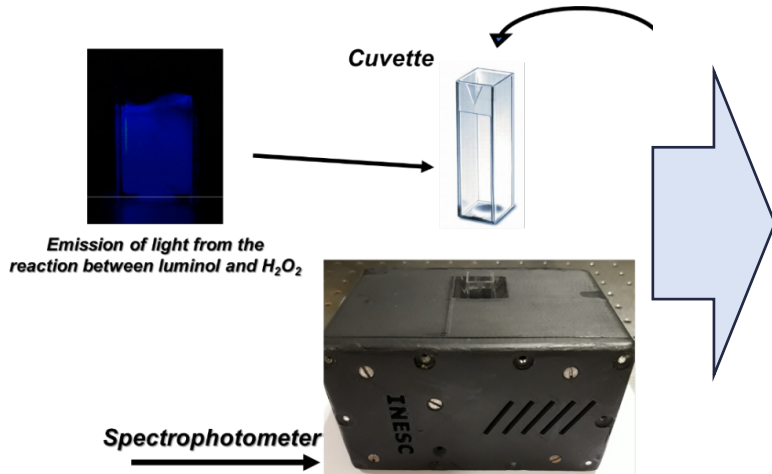

## SINGLE DETECTOR SYSTEM

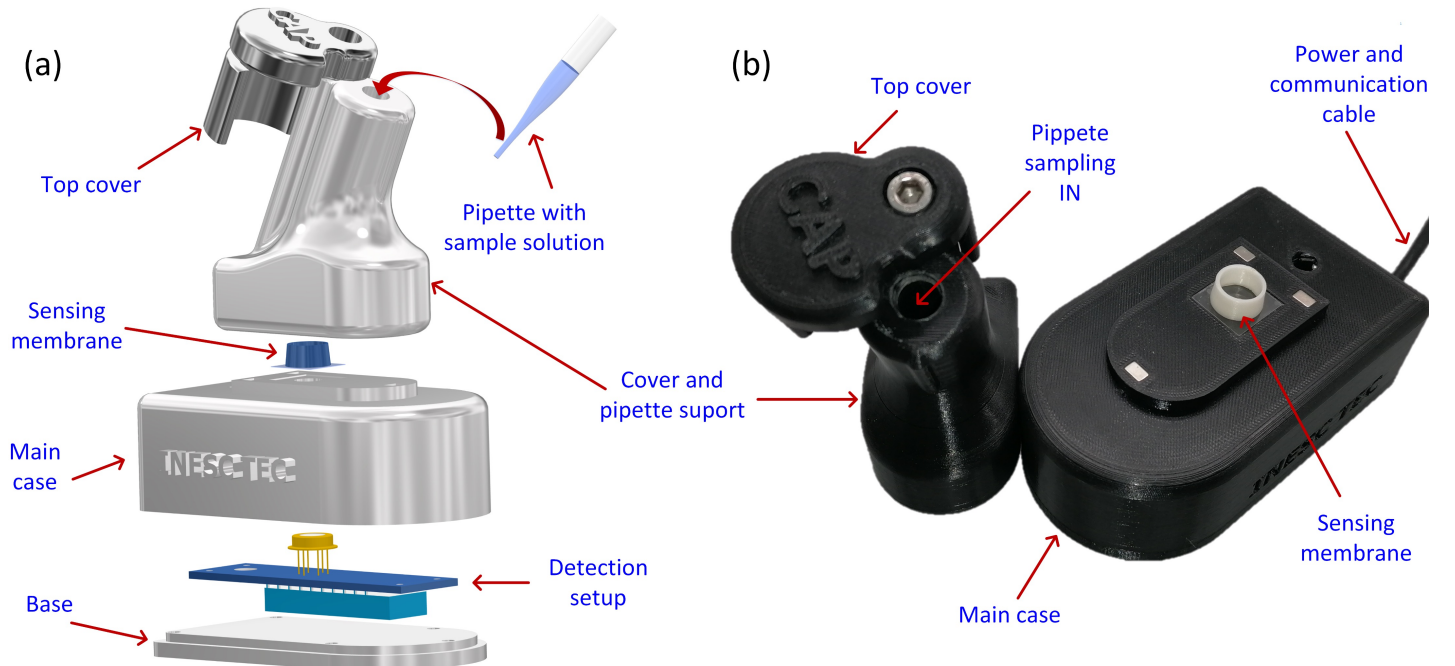

• Food4you - Real-time monitoring of fresh food quality with optical sensors

Final prototype



End user control interface

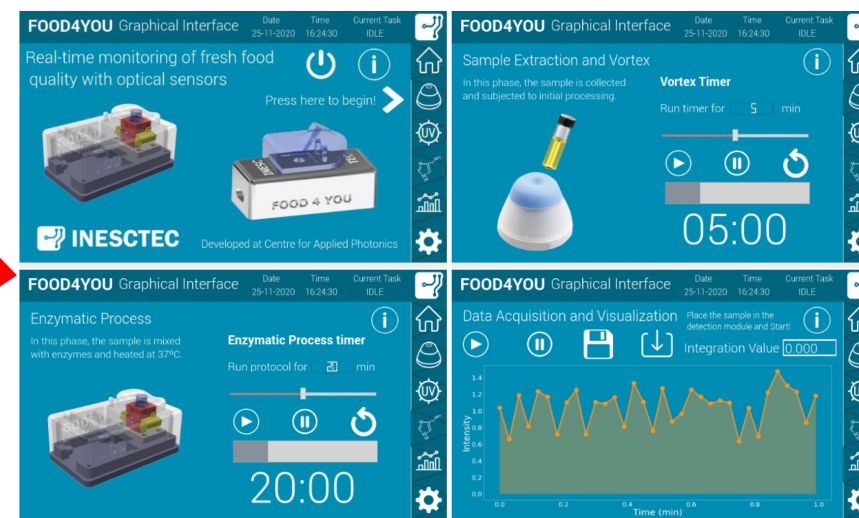

MAIN FEATURES

- Sample preparation, contains a vortex and a fully developed magnetic stirrer, UV sterilization setup and a mini oven.
- Disposable sensing membranes
- Signal detection with a high sensitive developed solution.
- Portable unit. Single case, can be moved to the measurement site.
- User friendly control unit
- Direct measurement of H2O2 in rain water.
- Monitoring of milk samples to detect fraud.



**WANT TO KNOW MORE?**

**YOU ARE INVITED TO COME AND VISIT OUR LABS!**

